



Zone Control Panels

The Original "Boiler Room in a Box"

CMB

Prefabricated Zone Control Panel. Designed for use with high efficiency condensing /or modulating boilers.



Application

Capable of delivering 100 MBH, the CMB panel was designed specifically to work in conjunction with today's condensing and or modulating boilers in hydronic heating systems. The CMB bridges the gap between the heat source and the heat emitters, interfacing with the system operating controls that are integral to these high efficiency boilers.

Function

The CMB is available with your choice of 3, 4, or 5 low temperature zones. Each zone circuit can supply a remote manifold with up to five loops. Flow to each zone is controlled by a slow-acting zone valve which eliminates the water hammer effect commonly experienced with quick acting valves. Each zone is energized by a factory supplied thermostat.

In addition to the main system circulator a second circulator is supplied to control the flow to an indirect water heater. This circulator is set up to work with the boilers' DHW priority system.

The CMB is equipped with a terminal strip that is pre-wired to accept input signals from thermostats and a DHW aquastat.

The terminal strip also provides connections for a heat or DHW signal to the boiler.

The CMB is equipped with an air eliminator and comes with a fill valve and an expansion tank connection.

Options

Each panel can be supplied with a combination of standard zone valves (2.5 gpm) or high capacity zone valves (3.5 gpm). Refer to the following chart for allowable combinations. Total flow must not exceed panel capacity of 10 gpm.

3 ZONES low/high	3/0	2/1	0/3
4 ZONES low/high	4/0	3/1	2/2
5 ZONES low/high	5/0	4/1	

Construction

All CMB's components are in a wall mounted panel housed in a powder-coated enclosure. All components within the panel are selected to optimize their interrelated quality and functionality.

Every CMB is leak-tested under water pressure prior to leaving the factory. All components and wiring in control circuit are thoroughly inspected and

function tested. Each panel is ETL listed and complies with the requirements of CAN/CSA-C22.2

FEATURES AND BENEFITS

- **Pre-Engineered**
All ZCP products are designed in accordance with accepted engineering practices and industry standard hydronic principles to provide efficient and reliable operation
- **Pre-Assembled and Tested**
Factory assembled using equipment specially designed for accuracy and uniformity.
- **Pre-Wired to Simplify Installation**
All controls are pre-wired and function tested to simplify installation. Line voltage to the panels is delivered by a standard 15 amp receptacle and a factory wired cord with plug.
- **Compact, Packaged**
Fill valve, air elimination, and expansion tank connections (supplied with the CMB) minimize the need for additional field piping.
- **Modern Enclosure**
The factory-supplied, powder-coated enclosure provides protection from hot pipes and electrical controls, and discourages tampering.
- **Approvals**
The ETL listing confirms compliance with CAN/CSA-C22.2 No.14 & UL508, and provides assurance that relevant safety standards have been met.

CMB

APPLICATION EXAMPLE

CONDENSING/ MODULATING BOILER PANEL

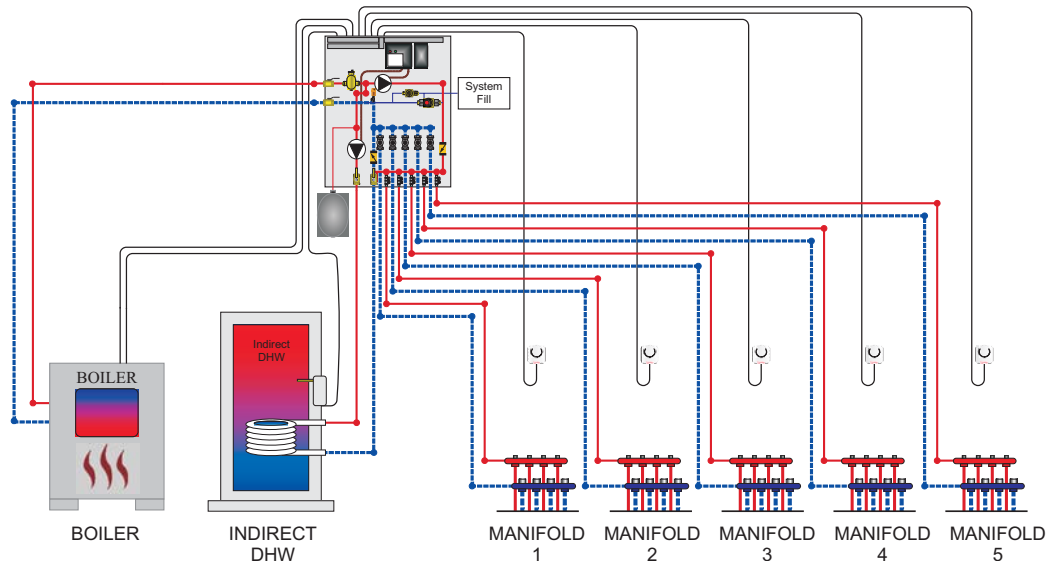

Standard Equipment: Air eliminator, air vent, fill valve, expansion tank connection, pressure differential valve, zone balancing and isolation valves, zone valves, thermostats, flow check valve, heating circulator, indirect DHW circulator, isolation valves, power pack, zone control, terminal strip, 115 V pre-wired cord with plug, all enclosed in a powder coated enclosure.



ETL listed
complies with CAN/CSA-
C22.2
No. 14 & UL-508

TECHNICAL DATA	CMB5L1H	CMB4L1H	CMB3L1H
Panel Output ¹⁾ :	100,000 btu/hr	100,000 btu/hr	100,000 btu/hr
Max. Flow:	10 gpm	10 gpm	10 gpm
Max. Flow per Zone ²⁾ :	2.5 gpm	2.5 gpm	2.5 gpm
Heating Zones:	5	4	3
Available Head/Heating:	18 ft	18 ft	18 ft
Available Head/DHW:	10 ft	10 ft	10 ft
Maximum Operating Pressure:	100 psi	100 psi	100 psi
Maximum Ambient Temperature:	120 Deg. F	120 Deg. F	120 Deg. F
Max. Supply From Heat Source:	180 Deg. F	180 Deg. F	180 Deg. F
Max. Supply to Radiant System:	180 Deg. F	180 Deg. F	180 Deg. F
Weight incl. Cover::	165 lb	165 lb	165 lb
Cover:	COATED STEEL		
Connections:	SUPPLY FROM HEAT SOURCE (PRIMARY) - 1" SOLDER RETURN TO HEAT SOURCE (PRIMARY) - 1" SOLDER SYSTEM RETURN (SECONDARY) - 1/2" SOLDER SYSTEM SUPPLY (SECONDARY) - 1/2" FIP DHW RETURN AND SUPPLY - 1" SOLDER COLD WATER FILL - 1/2" FIP EXPANSION TANK CONNECTION - 3/4" FIP		
Power Supply:	Pre-wired cable plugs into standard 120V 15A dedicated receptacle.		

Dimensions/Weight:COP

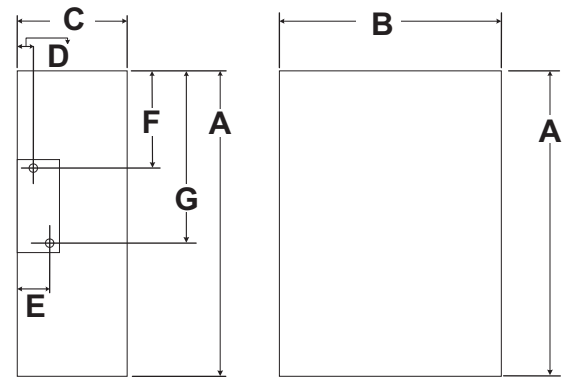

A	B	C	D	E	F	G
36-1/8	26-1/8	13	3-1/2	6	12 1/2	17 1/2

¹⁾ Panel output based on a temperature differential of 20° F between supply and return (secondary circuit).

²⁾ Maximum flow based on up to five loops (max. 250 feet in length) of 1/2" PEX radiant tubing with a maximum of 0.6 USGPM per loop.

Heat transfer fluid comprised of 100% water solution.

ZCP Mfg Inc.

8034, 11500-35th St. SE
Calgary AB T2Z 3W4
Tel: 403-236-9560

Fax: 403-236-0826
Email: lyndon@zcpinc.com
website: www.zcpinc.com

The Art of Comfort

